

# hyperMILL<sup>®</sup>

for SOLIDWORKS

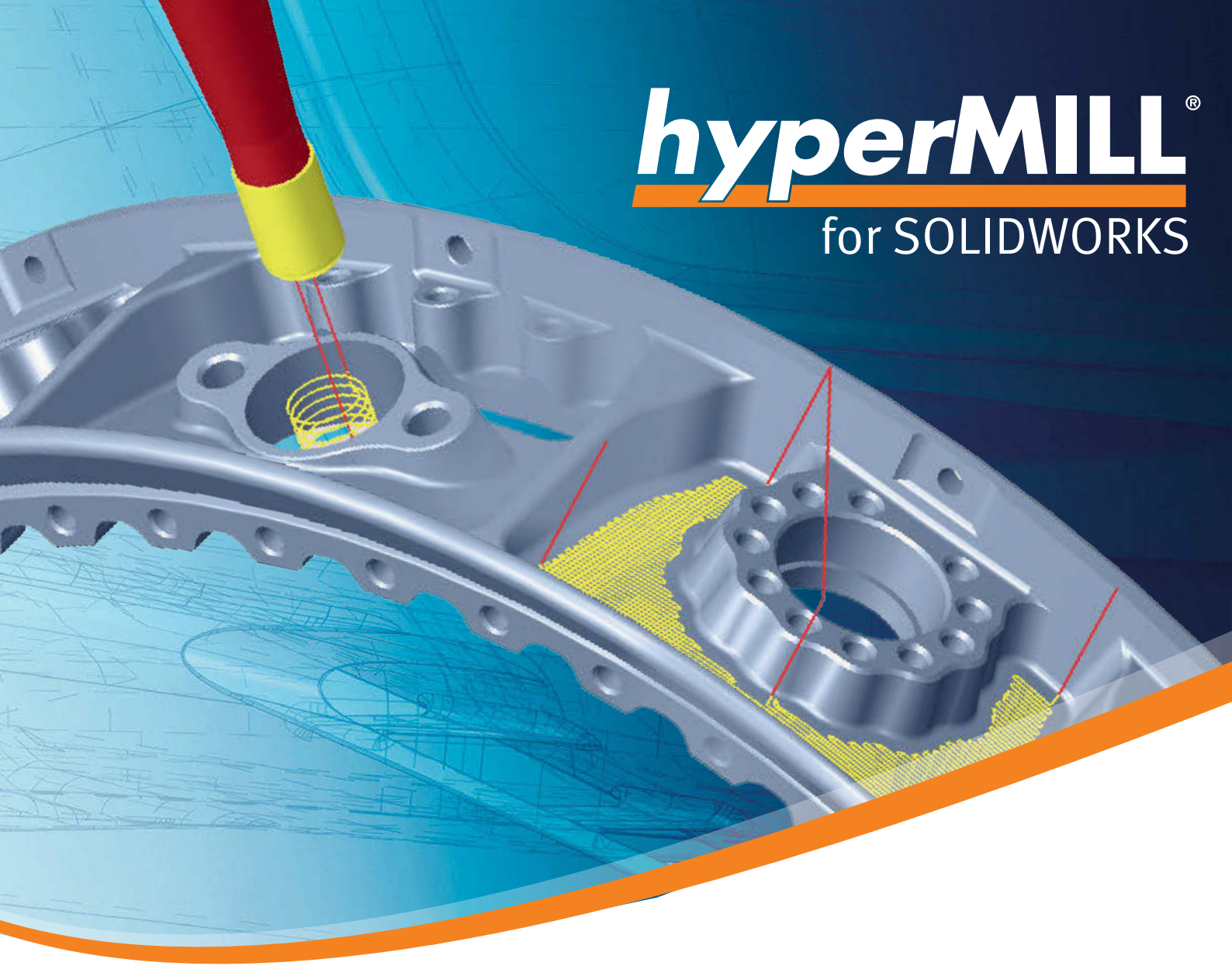

CERTIFIED  
Gold  
Product

 SOLIDWORKS

**Forward-looking**  
technologies.  
Seamlessly integrated.

CAD INTEGRATION

 **OPEN MIND**  
THE CAM FORCE



## *hyperMILL*<sup>®</sup> – The most comprehensive range of CAM strategies under a single interface

*hyperMILL*<sup>®</sup> is certified as a Gold Product by SOLIDWORKS. This means that our CAM solution meets the strictest requirements with regard to integration, reliability and user friendliness. The *hyperMILL*<sup>®</sup> user interface is fully integrated into SOLIDWORKS. CAM data is associatively linked with the geometric data from SOLIDWORKS. And *hyperMILL*<sup>®</sup> fulfils another important prerequisite for certification: the successful use of the software solution by *hyperMILL*<sup>®</sup> reference customers.

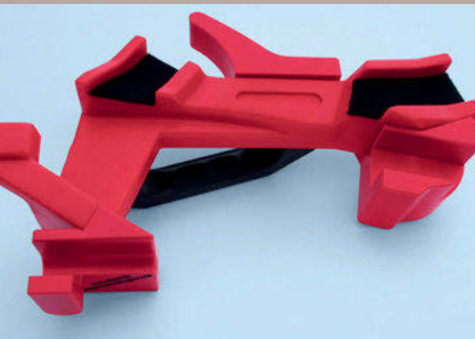

*hyperMILL*<sup>®</sup>  
for SOLIDWORKS:  
Used successfully  
by numerous  
customers.

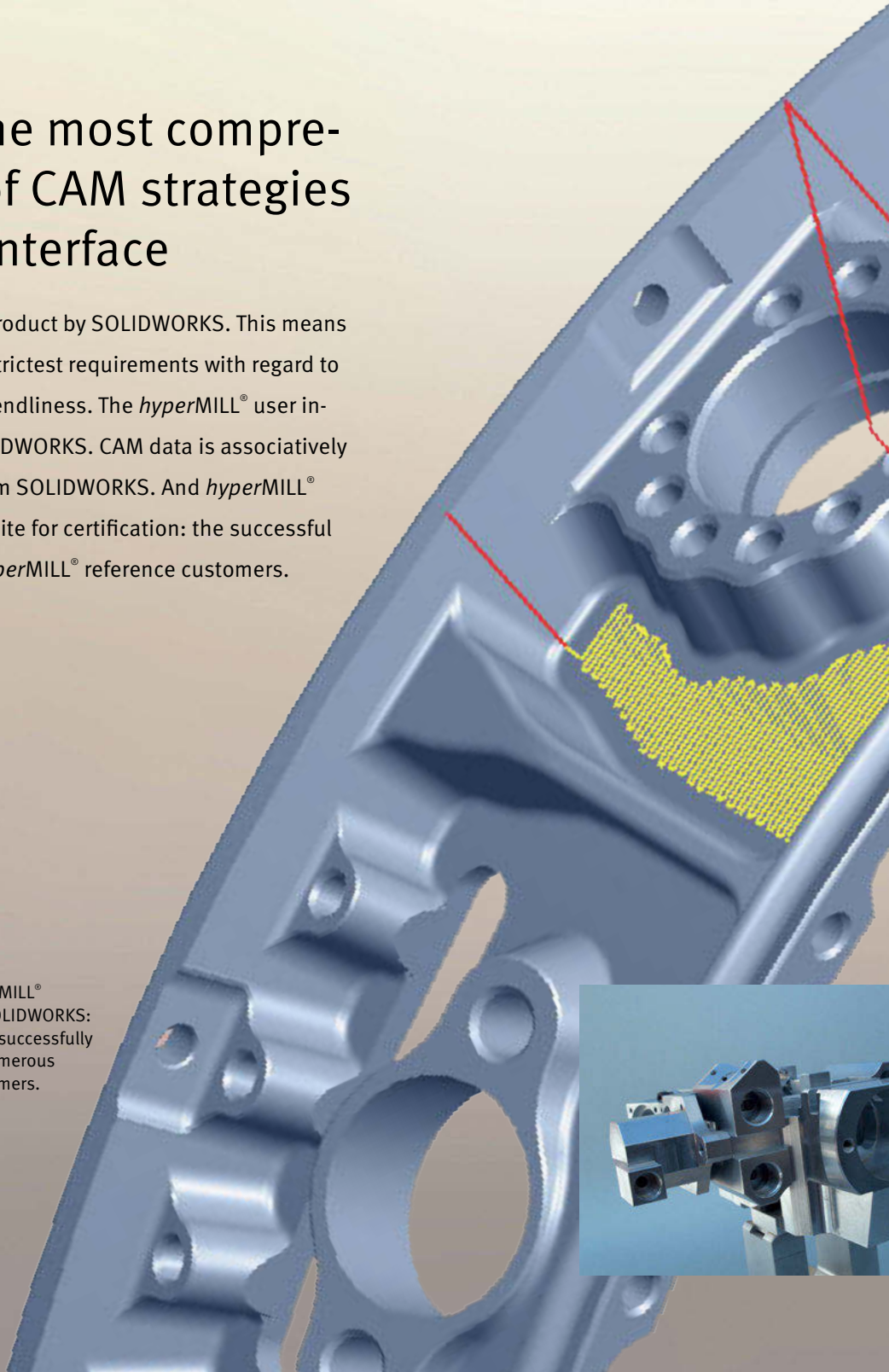
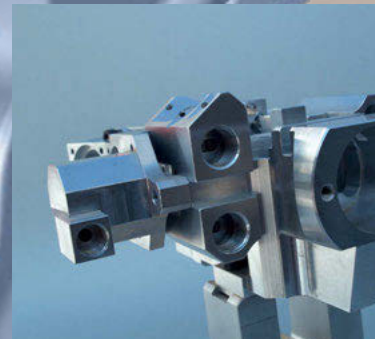

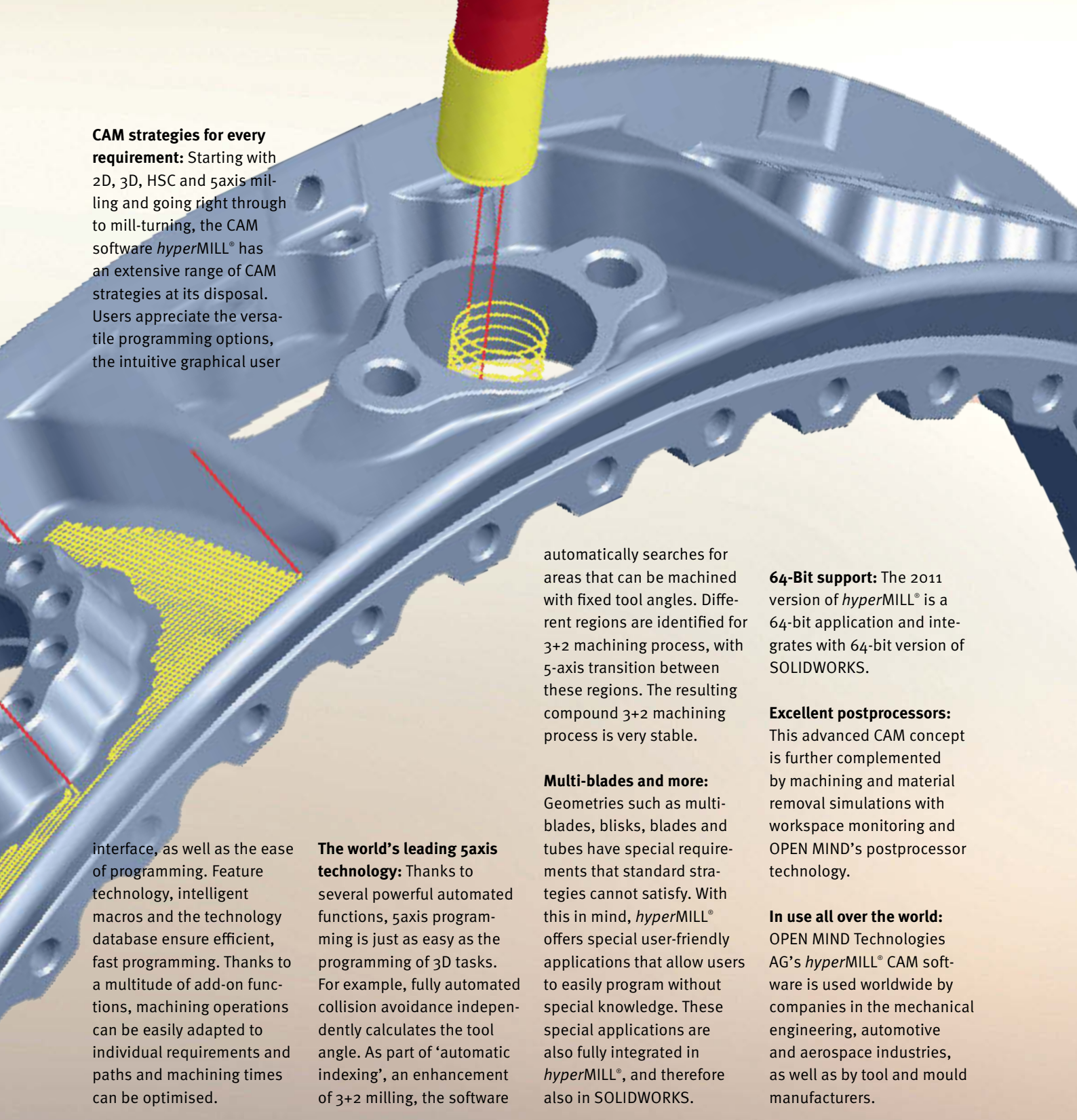

**CAM strategies for every requirement:** Starting with 2D, 3D, HSC and 5axis milling and going right through to mill-turning, the CAM software *hyperMILL*® has an extensive range of CAM strategies at its disposal. Users appreciate the versatile programming options, the intuitive graphical user

interface, as well as the ease of programming. Feature technology, intelligent macros and the technology database ensure efficient, fast programming. Thanks to a multitude of add-on functions, machining operations can be easily adapted to individual requirements and paths and machining times can be optimised.

**The world's leading 5axis technology:** Thanks to several powerful automated functions, 5axis programming is just as easy as the programming of 3D tasks. For example, fully automated collision avoidance independently calculates the tool angle. As part of 'automatic indexing', an enhancement of 3+2 milling, the software

automatically searches for areas that can be machined with fixed tool angles. Different regions are identified for 3+2 machining process, with 5-axis transition between these regions. The resulting compound 3+2 machining process is very stable.

**Multi-blades and more:** Geometries such as multi-blades, blisks, blades and tubes have special requirements that standard strategies cannot satisfy. With this in mind, *hyperMILL*® offers special user-friendly applications that allow users to easily program without special knowledge. These special applications are also fully integrated in *hyperMILL*®, and therefore also in SOLIDWORKS.

**64-Bit support:** The 2011 version of *hyperMILL*® is a 64-bit application and integrates with 64-bit version of SOLIDWORKS.

**Excellent postprocessors:** This advanced CAM concept is further complemented by machining and material removal simulations with workspace monitoring and OPEN MIND's postprocessor technology.

**In use all over the world:** OPEN MIND Technologies AG's *hyperMILL*® CAM software is used worldwide by companies in the mechanical engineering, automotive and aerospace industries, as well as by tool and mould manufacturers.



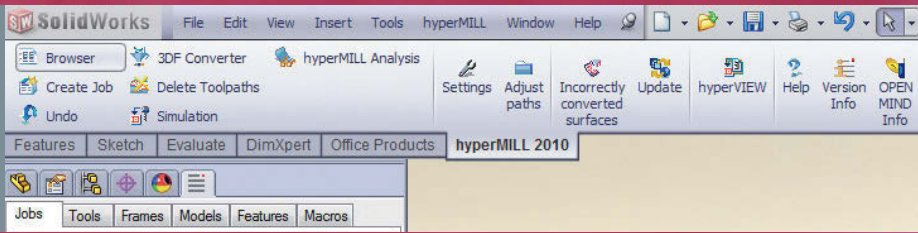

## Efficient machining with integrated processes

Thanks to the *hyperMILL*<sup>®</sup> integration, SOLIDWORKS users can take advantage of arguably the most up-to-date CAM programming system within their familiar software environment. The user runs CAD and CAM programs simultaneously having access to all functions. The solution's familiar look and feel ensures fast learning and user-friendly programming. In this intelligent environment, efficient and reliable production is guaranteed through tightly integrated processes.

Wilhelm Lippold GmbH & Co KG in Bremen, Germany, develops special tooling equipment using a process chain that includes reverse engineering, design and machinery on modern 5-axis machines. [www.lippold-sonderwerkzeugbau.de](http://www.lippold-sonderwerkzeugbau.de)



**Scanning:** The object is scanned with a laser and displayed on the monitor. High resolution also allows complex models to be captured with great accuracy.

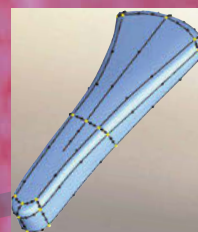

**Surface reconstruction:** The point cloud is transformed into a surface model that is used for subsequent machining processes. The result is output as a STEP or IGES file.



**Design:** Lippold GmbH & Co. KG also uses SOLIDWORKS as a CAD system in reverse engineering.

**Single part and assembly mode:** *hyperMILL*® allows you to work using both the single part and assembly modes. Clamps and holders are taken into account during collision checking and the *hyperMILL*® data is saved together with the relevant machining modules.

**Take advantage of geometric features:** The feature technology provided by *hyperMILL*® allows geometries from

the CAD system to be used for CAM programming. For example, holes, threads and pockets can be detected on solids and surface models thanks to automatic feature recognition. Furthermore, machining strategies and tools can be linked with features to create technology macros. These macros are stored in a dedicated technology database.

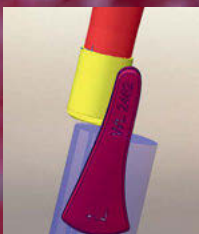

**Simple start-up:** In SOLIDWORKS, *hyperMILL*® is launched directly via the *hyperMILL*® button. Users can freely switch between the CAD and the CAM systems at any stage.

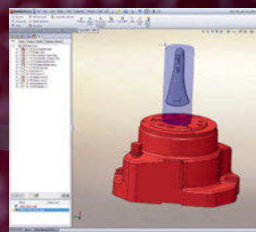

**Single database:** The tightly integrated software solution facilitates continuous processes thanks to a unified database. Both the CAD and CAM systems use the same data model. This eliminates data import issues as well as read/write errors.



**Machine/machining:** 5axis simultaneous milling strategies are used to manufacture complex special tools made. These strategies enable fast and efficient machining.



**End product:** The holder for tool mounting is manufactured using several milled individual parts.

# Innovative CAM strategies for greater programming flexibility

Thanks to the wide range of strategies provided, even highly specialised parts can be machined quickly and efficiently. Functions such as tool path optimisation ensure minimal machining times.

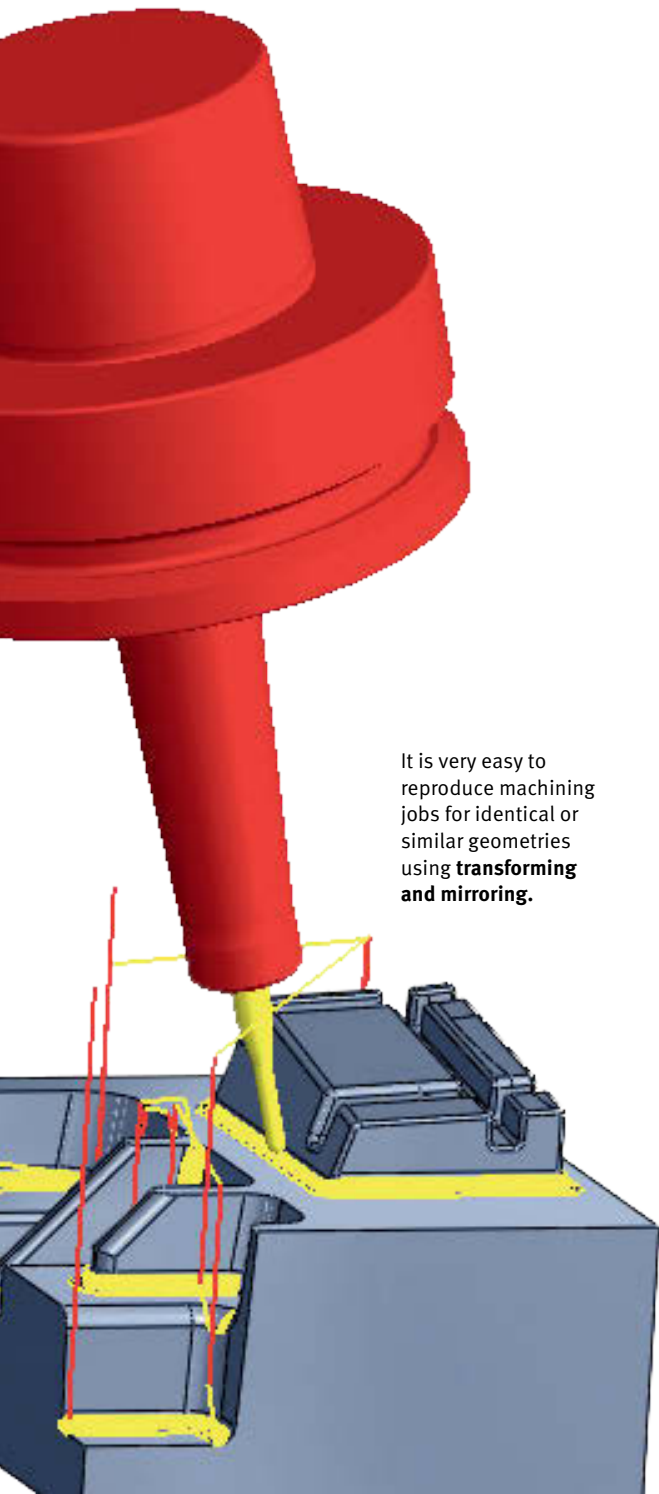

It is very easy to reproduce machining jobs for identical or similar geometries using **transforming and mirroring**.

**2D machining:** offers the potential for even greater manufacturing efficiency. This includes functions such as contour milling with optimised traverse path and the fully integrated mill/turn module.

**3D machining:** *hyperMILL*® integrates proven strategies with a new level of quality. This is due to the fact that these strategies are supplemented by intelligent add-on functions that improve manufacturing results.

**5axis milling:** The 5axis technology in *hyperMILL*® often yields time savings of more than 25 per cent while lowering tool wear and increasing contour accuracy.

**Special applications:** The Blade, Multi-Blade and Tube packages allow special applications to be programmed quickly and easily.

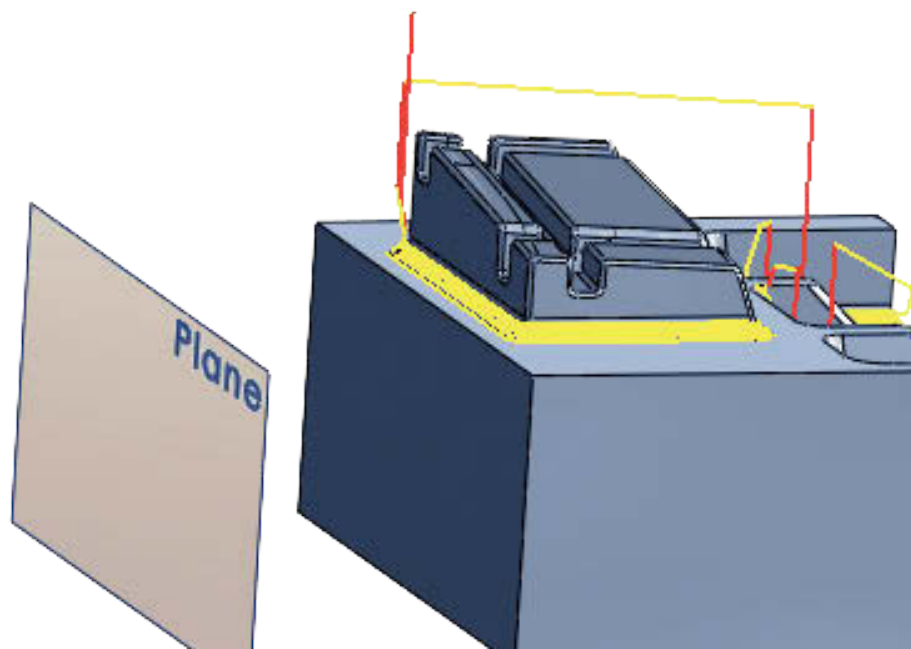

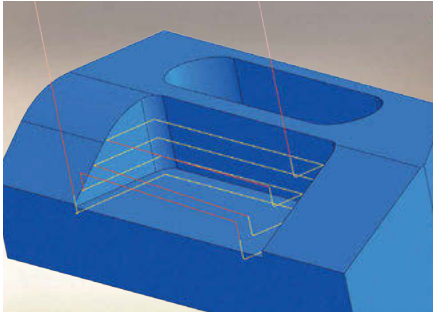

The new 2D contour milling cycle offers superb optimisation possibilities to reduce both programming and machining times.

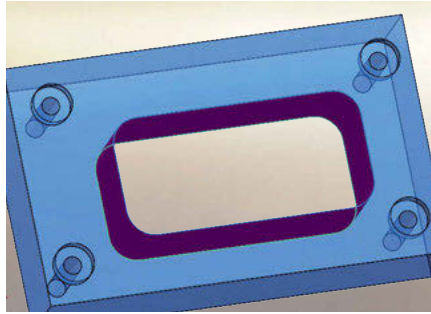

In addition to closed pockets, pockets with islands and pockets with open sides, *hyperMILL*® now also detects breakthroughs.

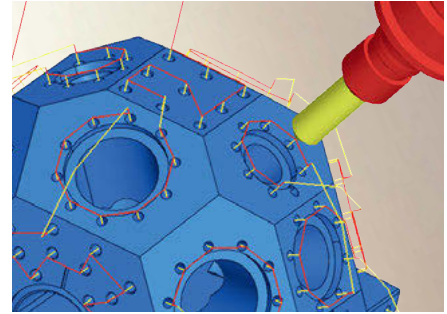

The 5axis drilling function is used to simply and automatically program drilling jobs with different tool angles in a single operation.

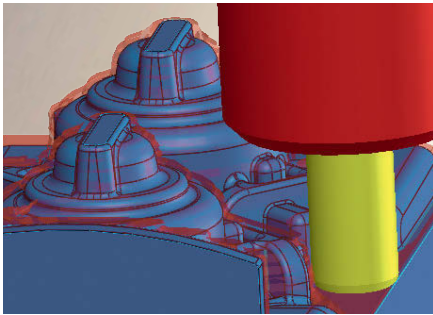

During stock roughing, stock tracking ensures active collision avoidance. The tool path is moved laterally in the case of a potential collision between the stock and the tool shank or holder.

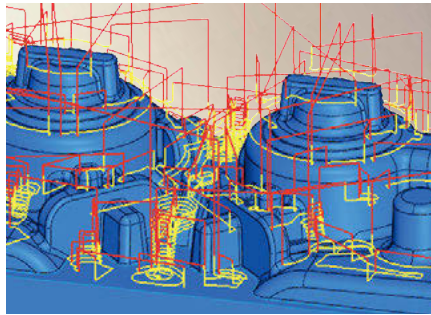

Referencing to previous rest machining allows areas that have not been machined to be cleared very quickly using a new tool and/or tool inclination.

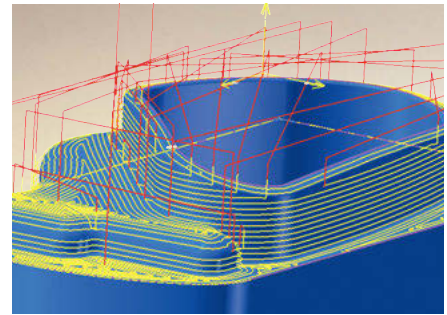

Z-level finishing and profile finishing can be combined for complete finishing jobs. As a result, machining can be automatically adapted to the requirements of individual model areas.

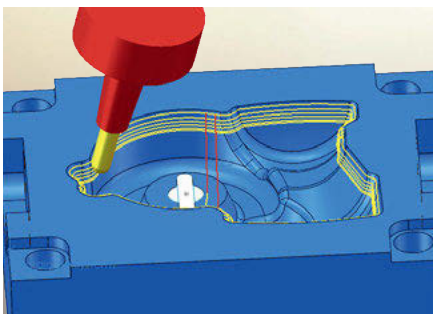

Steep areas can be machined plane by plane using 5axis Z-level finishing. Automatic collision avoidance ensures process reliability.

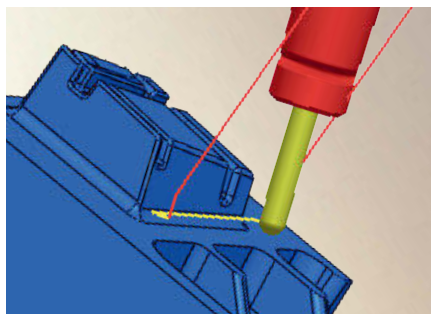

When using 5axis swarf cutting, the workpiece surface is machined with the tool flank. Large step-downs between paths reduce milling times.

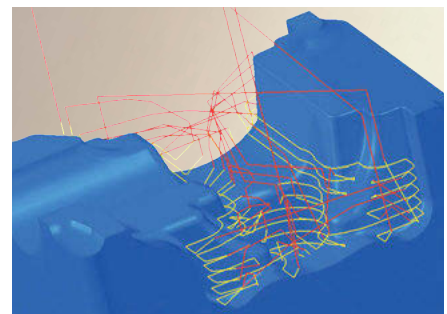

Automatic approach and retract macros search for the best approach and retract movements. They help to avoid entry markings and simplify programming.

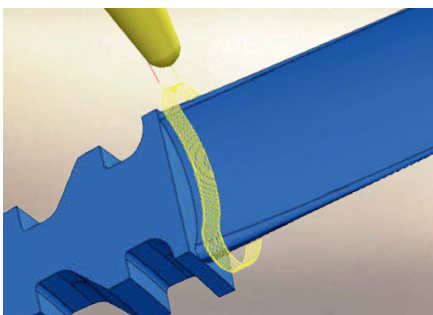

The Blade package offers optimised machining strategies for complete machining from top to bottom and the blade in the middle.

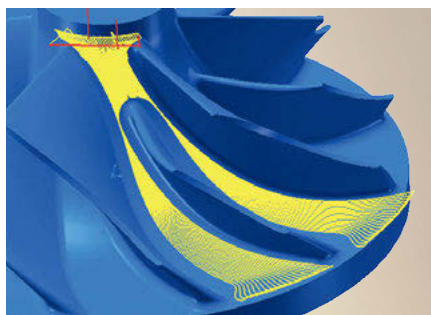

The automated functions in the Multi-Blade package minimise the number of process parameters that need to be defined.



The Tube package contains optimised machining strategies specifically developed for this type of machining. You can work directly on digitised surfaces.

- Headquarters** OPEN MIND Technologies AG  
Argelsrieder Feld 5 • 82234 Wessling • Germany  
Phone: +49 8153 933-500  
E-mail: Info.Europe@openmind-tech.com  
Support.Europe@openmind-tech.com
- UK** OPEN MIND Technologies UK Ltd.  
Units 1 and 2 • Bicester Business Park  
Telford Road • Bicester • Oxfordshire OX26 4LN • UK  
Phone: +44 1869 290003  
E-mail: Info.UK@openmind-tech.com
- USA** OPEN MIND Technologies USA, Inc.  
1492 Highland Avenue, Unit 3 • Needham MA 02492 • USA  
Phone: +1 888 516-1232  
E-mail: Info.Americas@openmind-tech.com
- Brazil** OPEN MIND Tecnologia Brasil LTDA  
Av. Andromeda, 885 SL2021  
06473-000 • Alphaville Empresarial  
Barueri • Sao Paulo • Brasil  
Phone: +55 11 2424 8580  
E-mail: Info.Brazil@openmind-tech.com
- Asia Pacific** OPEN MIND Technologies Asia Pacific Pte. Ltd.  
33 Ubi Avenue 3 #06-32 • Vertex (Tower B)  
Singapore 408868 • Singapore  
Phone: +65 6742 95-56  
E-mail: Info.Asia@openmind-tech.com
- China** OPEN MIND Technologies China Co. Ltd.  
Suite 1608 • Zhong Rong International Plaza  
No. 1088 South Pudong Road  
Shanghai 200120 • China  
Phone: +86 21 588765-72  
E-mail: Info.China@openmind-tech.com
- India** OPEN MIND CAD/CAM Technologies India Pvt. Ltd.  
#369/4, 1<sup>st</sup> Floor • 2<sup>nd</sup> Cross • 1<sup>st</sup> 'B' Main Road  
7<sup>th</sup> Block, Jayanagar (W) Bangalore – 560070  
Karnataka • India  
Phone: +91 80 2676 6999  
E-mail: Info.India@openmind-tech.com
- Japan** OPEN MIND Technologies Japan K.K.  
Misumi Bldg. 3F • 1-17-18, Kichijojihigashicho  
Musashino-shi • Tokyo 180-0002 • Japan  
Phone: +81 422 23-5305  
E-mail: info.jp@openmind-tech.co.jp
- Taiwan** OPEN MIND Technologies Taiwan Inc.  
Rm. F, 4F., No.1, Yuandong Rd., Banqiao Dist.  
New Taipei City 22063 • Taiwan  
Phone: +886 2 2957-6898  
E-mail: Info.Taiwan@openmind-tech.com

OPEN MIND Technologies AG is represented worldwide with own subsidiaries and through competent partners and is a member of the Mensch und Maschine technology group, [www.mum.de](http://www.mum.de)

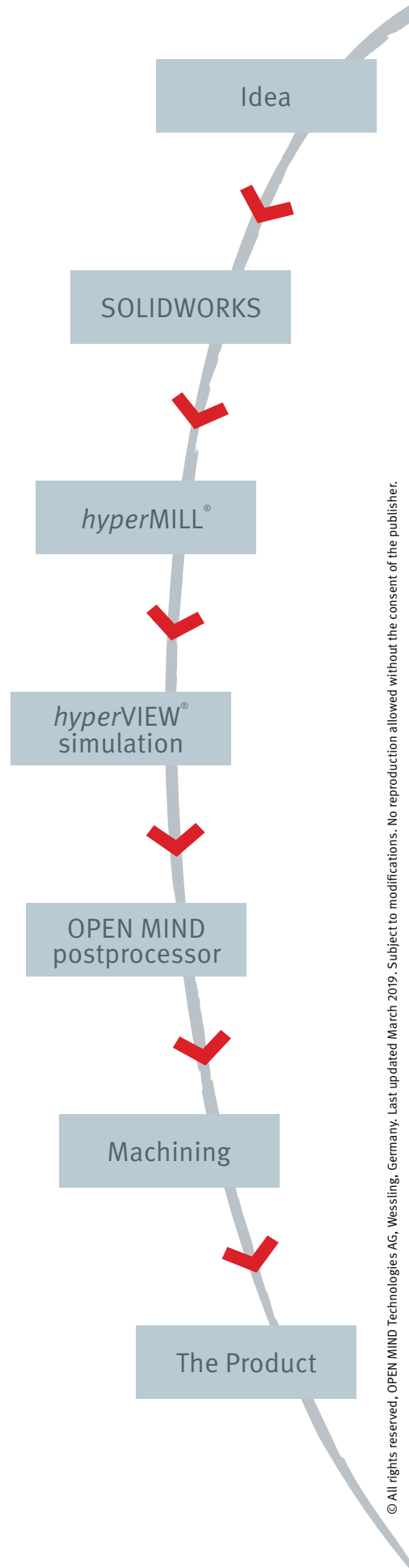

We push machining to the limit

[www.openmind-tech.com](http://www.openmind-tech.com)